

STRAIGHT MALE JACK CRIMP TYPE

CABLE 6/75 S PACK500

R197.134.A26

Series : SMB CARLOCK

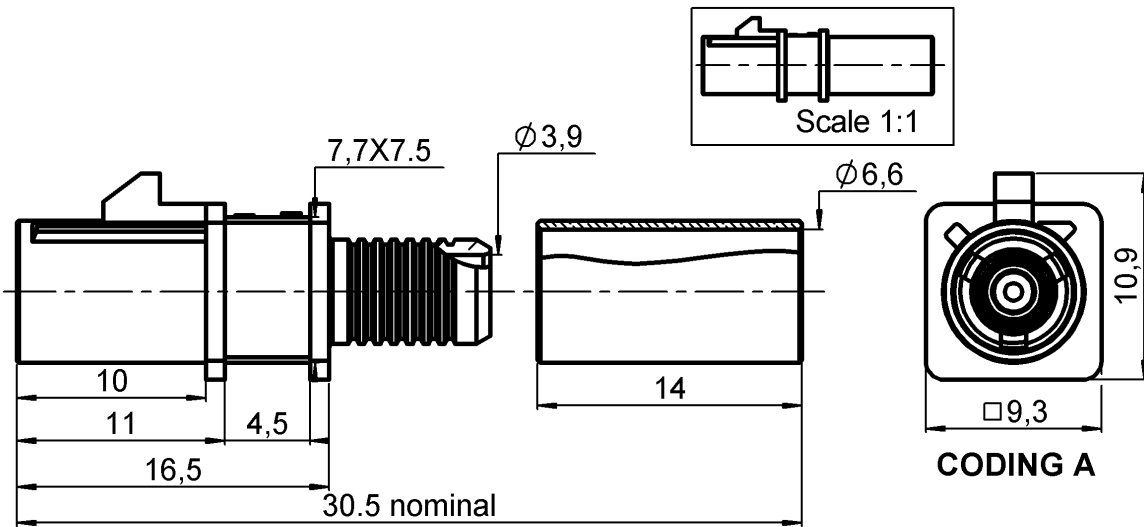

Stamped and formed center contact to be ordered and delivered separately P/N : 250.56.172 rev B

- Tape & reel packaging by 10000
- Diameter of the reel: 600 mm
- Pitch between contacts: 5 mm
- Plating for contact area :Gold 0.5 over Nickel2
- Plating for crimp area :Tin 1 over Nickel 2

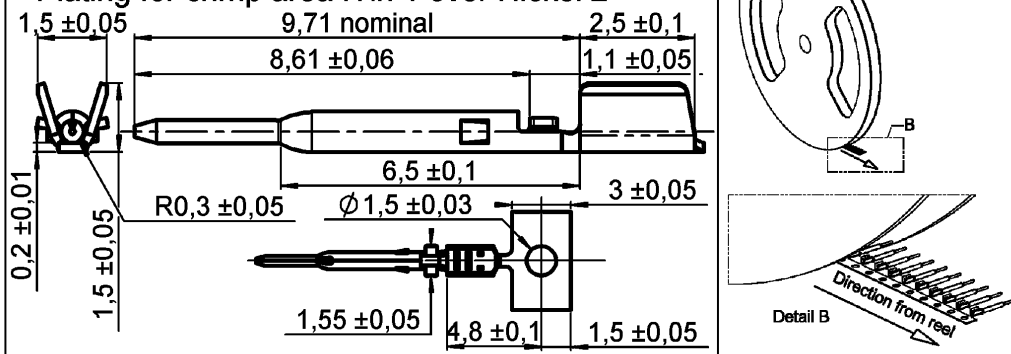

All dimensions are in mm.



COMPONENTS	MATERIALS	PLATING (µm)	
BODY	BRASS	NICKEL 2	
CENTER CONTACT	BRONZE	SELECTIVE GOLD+ SELECTIVE TIN	
OUTER CONTACT	-	-	
INSULATOR	TPX	-	
GASKET	-	-	
OTHERS PARTS	BRASS	NICKEL 2	
-	-	-	
-	-	-	
HOUSING	PA6.6 GF15 (POLYAMIDE)	UL CLASSIFICATION	COLOR
		UL 94 V-2	BLACK RAL 9005

Issue : 0637 C

In the effort to improve our products, we reserve the right to make changes judged to be necessary.



STRAIGHT MALE JACK CRIMP TYPE

R197.134.A26

CABLE 6/75 S PACK500

Series : **SMB CARLOCK**

PACKAGING

Standard	Unit	Other
500	'W' option	Contact us

SPECIFICATION

SAE/USCAR-17 Rev.1 (October 2002)
SAE/USCAR-2 Rev.3 (February 2001)
SAE/USCAR-18 Rev.2 (January 2003)

ELECTRICAL CHARACTERISTICS

Impedance		50 Ω
Frequency		0-1 GHz
VSWR	1.60 +	0,0000 x F(GHz) Maxi
Insertion loss		0.3 √F(GHz) dB Maxi
RF leakage	- (NA - F(GHz)) dB Maxi
Voltage rating		335 Veff Maxi
Dielectric withstanding voltage		1000 Veff mini
Insulation resistance		1000 MΩ mini

CABLE ASSEMBLY

Stripping	a	b	c	d	e	f
mm	3,60	8,50	14,6	0,00	10,8	0,00

Assembly instruction : **See Pages 3 & 4**

Recommended cable(s)

- RG59/U TFC/Amphenol
Part number T59PN95C-VB
- RG59/U CommScope
Part number # AMC-59

Characteristics indicated on this data sheet are those that can be achieved with the highest performance cable. Intrinsic limitations of the cable may diminish the performance of the assembly

Cable retention

- pull off **150** N mini
- torque **NA** N.cm

MECHANICAL CHARACTERISTICS

Center contact retention		
Axial force – Mating end	10	N mini
Axial force – Opposite end	10	N mini
Torque	NA	N.cm mini

TOOLING

Part Number	Description	Hexagon
.	.	.
R282.293.000	CRIMPING TOOL	
R282.235.013	CRIMPING DIES	Hex 6.48
R282.223.000	CRIMPING TOOL	Hex 6.48

Recommended torque		
Mating	NA	N.cm
Panel nut	NA	N.cm
Clamp nut	NA	N.cm
A/F clamp nut	0,0000	mm

Mating life	25	Cycles mini
Weight	3,7200	g

OTHER CHARACTERISTICS

* Depends on the cable used

ENVIRONMENTAL

Operating temperature	-40/+90*	° C
Hermetic seal	NA	Atm.cm3/s
Panel leakage	NA	

Issue : **0637 C**

In the effort to improve our products, we reserve the right to make changes judged to be necessary.



STRAIGHT MALE JACK CRIMP TYPE

R197.134.A26

CABLE 6/75 S PACK500

Series : SMB CARLOCK

RECOMMENDED MOUNTING PROCEDURE

1

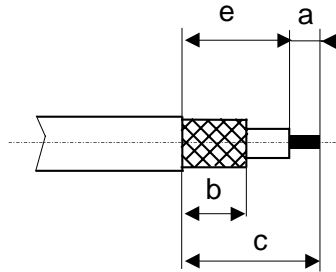

a : inner conductor stripping dimension.
b : braid stripping dimension.
c : jacket stripping dimension.
e : dielectric stripping dimension.

• Strip the cable

2

• Crimp the centre contact with crimping dies as described ,using standard mini applicator.

• check the crimping height $B=0.78 \pm 0.03$ and the crimping width $A=1 \pm 0.05$ of the center contact.

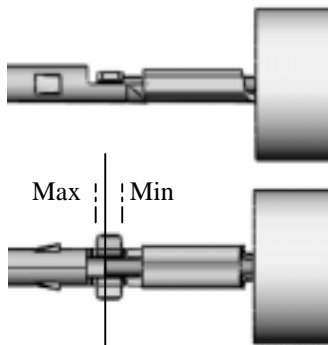
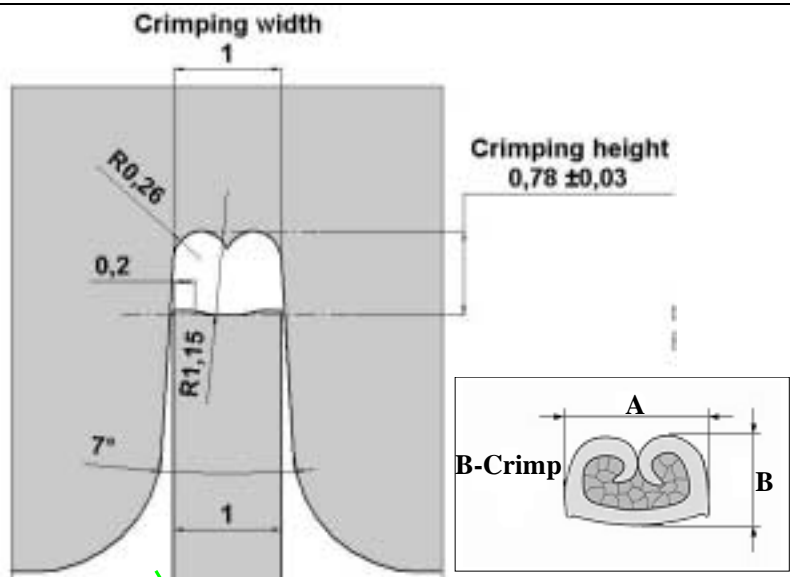
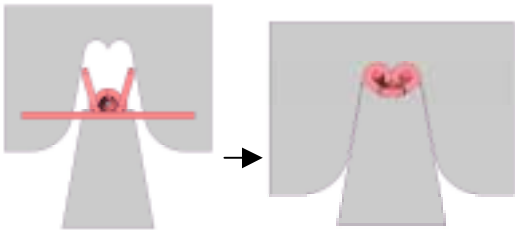

Visual checking
 The tip of the cable conductor must be within the width of the positive stop tap.

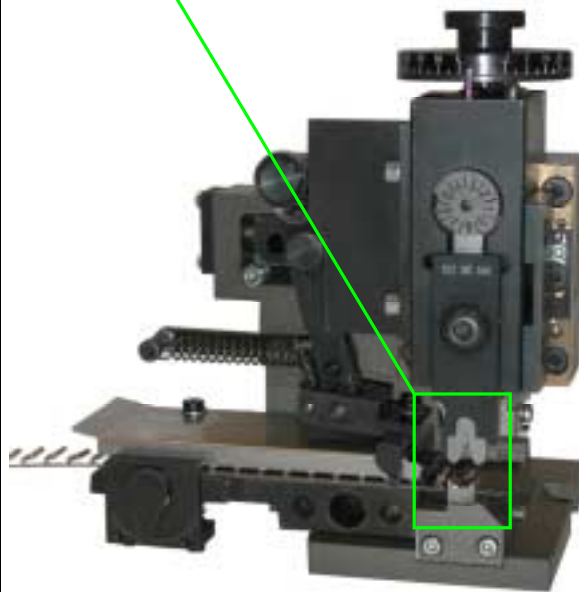

Mini applicator

Issue : 0637 C

In the effort to improve our products, we reserve the right to make changes judged to be necessary.





STRAIGHT MALE JACK CRIMP TYPE

R197.134.A26

CABLE 6/75 S PACK500

Series : SMB CARLOCK

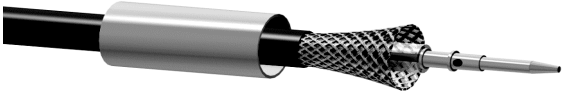
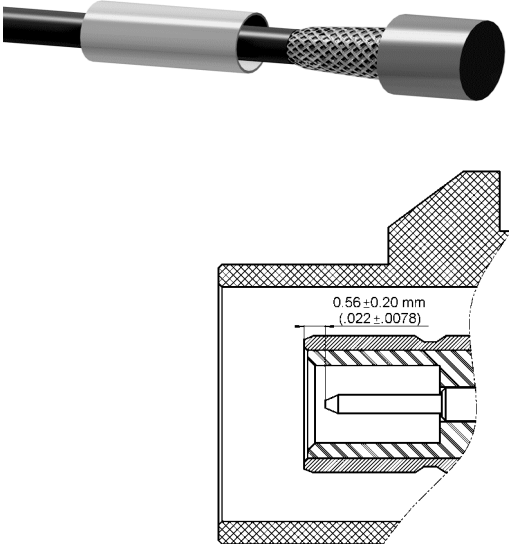
RECOMMENDED MOUNTING PROCEDURE

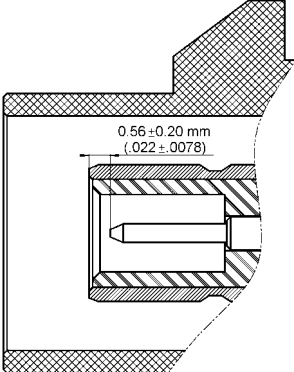
<p>3</p> <ul style="list-style-type: none"> • Slide the ferrule • Fan the braid 	
<p>4</p> <ul style="list-style-type: none"> • Insert gently the center contact into the insulator ; Be cautious you must feel first a force detente corresponding to the center contact barb insertion, and a second force stage corresponding to the center contact reaching its final location. Do not apply an excessive force on the center contact in order to avoid bad interface. A correct insertion force must lead to the interface dimension compliance. • Check the position of the center contact between the top of the insulator and the top of the center contact : 0.56 ± 0.2 	
<p>5</p> <ul style="list-style-type: none"> • Slide the ferrule over the braid • Crimp the ferrule (Hex 6.48) with crimping tool R282.223.000 or crimping tool R282.293.000 (M22520/5-01) + dies R282.235.013 (M22520/5-13). 	
<p>6</p> <ul style="list-style-type: none"> • Check the position of the center contact between the top of the body and the top of the center contact : 0.56 ± 0.20. 	

Issue : 0637 C

In the effort to improve our products, we reserve the right to make changes judged to be necessary.

